

Circuit Protection Design Considerations for LCD (Liquid Crystal Display) TV Power Supplies and I/O Ports

Advanced LCD technology has resulted in larger screens, wider viewing angles, and higher-quality video images. However, as LCD TV screens grow bigger, and brighter, they require more power to operate, increasing the need for more robust and reliable circuit protection techniques.

A variety of circuit protection devices can be used to help protect the LCD screen from damage caused by excessive current or voltage transients. Overcurrent protection may take the form of a fuse or a resettable PPTC (polymeric positive temperature coefficient) device. Deciding whether to specify a PPTC device or a single-use fuse depends on the LCD design, the types of threats the device may be exposed to, and the relevant safety requirements.

PPTC devices are commonly applied to circuits that experience high inrush currents on startup. PPTC devices are resilient to inrush currents and help eliminate the nuisance of blown fuses. Fuses are well suited to circuit designs where resettability is not desirable, or where faults occur only in a system failure condition. They are also a practical solution when soft-start circuitry is used to limit inrush current. Tyco Electronics provides both small form factor PPTC devices and single-use chip fuses, to give designers an array of overcurrent protection solutions.

Tyco Electronics also offers a broad range of overvoltage and ESD (electrostatic discharge) suppression devices, for a variety of LCD TV applications, as described below.

Multi-output Power Supply Protection

Switch-mode power supplies (SMPS) offer the size, weight, and energy-saving advantages required for consumer electronics and have continued to replace linear-regulators in many applications, including LCD TV monitors. However, because SMPS lack the inherent resistance of prior-generation designs, they often require more robust circuit protection.

PolySwitch radial-leaded overcurrent protection devices can help manufacturers meet UL60950-1/LPS (Limited Power Source) requirements for SMPS and help improve equipment safety and reliability.

The PolySwitch device has a low resistance value under

normal operating currents. In the event of an overcurrent condition, the device “trips” into a high resistance state. This increased resistance helps protect the equipment in the circuit by reducing the amount of current that can flow under the fault condition to a low, steady-state level. The device remains in its latched position until the fault is cleared. Once power to the circuit is cycled, the PolySwitch device resets and allows current flow to resume, restoring the circuit to normal operation.

While PolySwitch devices cannot prevent a fault from occurring, they respond quickly, limiting current to a safe level to help prevent collateral damage to downstream



components. Additionally, the small form factor of PolySwitch devices makes them easy to use in space-constrained applications.

As shown in Figure 1, the PolySwitch LVR device can be installed in series with the power input to help protect against damage resulting from electrical shorts, overloaded circuits or customer misuse. Additionally, a Metal Oxide Varistor (MOV) placed across the input helps provide overvoltage protection in the LED module.

The PolySwitch LVR device may also be placed after the MOV. Many equipment manufacturers prefer protection circuits combining resettable PolySwitch devices with upstream fail-

safe protection. In this example R1 is a ballast resistor used in combination with the protection circuit.

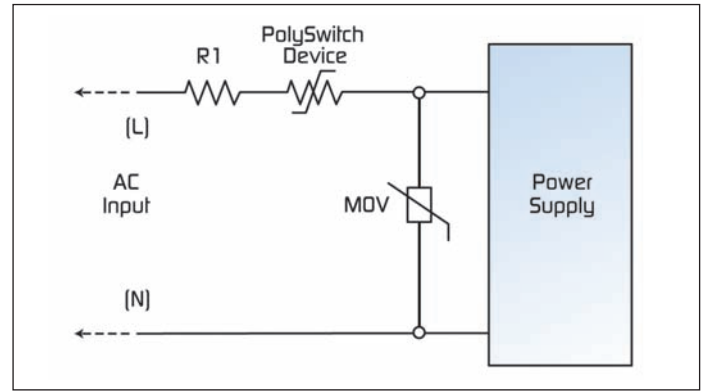

Figure 1. Typical circuit protection design for switch-mode power supplies

CCFL Backlighting Protection

Cold-cathode fluorescent lamps (CCFLs) provide high-efficiency backlighting of the LCD display. The lamp operates on high-voltage AC power and requires an efficient, high-voltage DC/AC inverter. As shown in Figure 2, power is derived from the 5V and 12V buses. The LCD controller itself and the surrounding controller logic are powered from the 5V bus. The LCD inverter and other electronics on the board are powered from the 12V bus.

Misconnections and mishandling can cause large overloads and short circuits to the system. In addition, component failures on the board can have devastating effects. Isolating critical circuits with fuses or PolySwitch devices helps prevent component damage during this type of fault and also helps manufacturers meet UL limited current requirements.

Many inverters incorporate “soft-start” circuitry to limit inrush currents, but, as the inverter ages, soft-start currents may rise over time. This increases the in-rush current and, without adequate protection, may result in the destruction or degradation of the primary power supply.

Tyco Electronics’ slow-blow surface-mount chip fuses help provide overcurrent protection on systems that experience large and frequent current surges as part of their normal operation. The small form factor fuses enhance electronic system reliability without compromising protection against high-current fault conditions with a time-lag design that helps prevent nuisance openings during pulsed- and high-inrush-current conditions.

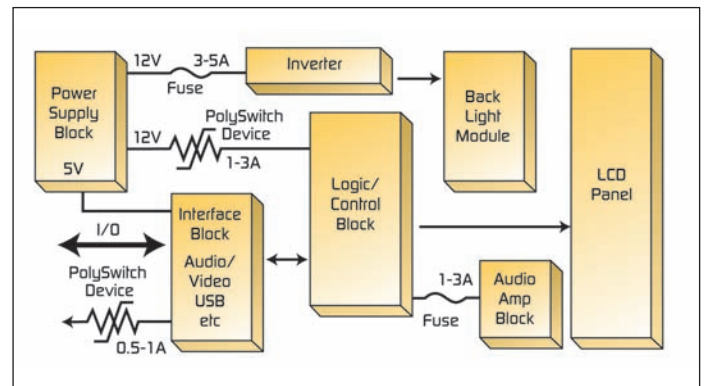

Figure 2. Slow-blow chip fuses and PolySwitch devices help provide overcurrent protection in CCFL backlighting applications

LED Backlighting Protection

LED backlighting enhances the viewing experience, offers more flexible backlight architectures, and enables thinner display designs than conventional cold-cathode fluorescent lamp (CCFL) technology. Other benefits include higher efficiency, reduced power consumption, a longer lifespan, enhanced durability, and better contrast ratios for clearer definition on-screen.

LEDs require precise power- and heat-management systems, since most of the electrical energy supplied to an LED is converted to heat rather than light. Without adequate thermal management, this heat will have a negative effect on both the LED’s lifespan and color output.

Power line coupled transients and surges can also reduce LED lifespan and many LED drivers are susceptible to damage resulting from improper DC voltage levels and polarity. LED driver outputs may also be damaged or destroyed by short circuits. Most LED drivers for LCD TV applications include built-in safety features, including thermal shutdown, as well as open and short LED detection. However, additional overcurrent protection devices may be needed to help protect integrated circuits (ICs) and other sensitive electronic components.

PolySwitch devices can also be used to help prevent thermal runaway, which may occur if the monitor’s cooling vent is

blocked. Due to its ability to detect and respond to overtemperature events, an appropriately mounted PolySwitch device, can interrupt current in the event the LCDs are operating without adequate ventilation.

Figure 3 shows the locations where PolySwitch devices can be located within an LCD TV monitor to help provide overcurrent protection. To fully leverage the PolySwitch device, it can be thermally bonded to the metal core circuit board or LED heat sink. If the LED is not equipped with built-in ESD protection, a PESD protection device placed in parallel with the LED can help protect against damage caused by ESD surges.

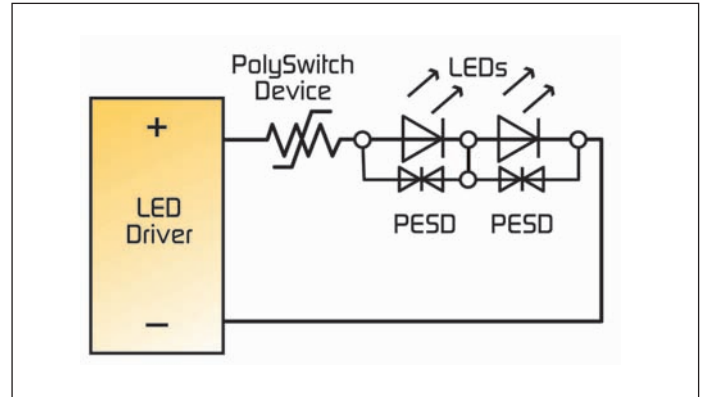

Figure 3. Overcurrent protection scheme for LED backlighting

Overcurrent and Overvoltage Protection for I/O Ports

I/O port protection helps protect components from short-circuit damage and improves reliability and customer safety. To meet regulatory agency requirements, I/O ports must supply a method of interrupting or limiting current in the event of an overload or short circuit.

As data rates increase and circuitry becomes smaller and more sensitive, protecting equipment from damage caused by circuit transients becomes even more critical. The HDMI, USB and DisplayPort specifications require that end-user-accessible, powered connectors implement overcurrent protection. The overcurrent protection device must be resettable, without user mechanical intervention, and its preset trip limit must be above allowable current transients in order to prevent false trips.

PolySwitch devices have demonstrated their effectiveness in a variety of high-speed interface applications. Like traditional fuses, they limit current after specified limits are exceeded. However, unlike a fuse, PolySwitch devices have the ability to reset after the fault is cleared and the power is cycled. Their low resistance, fast time-to-trip and small form factor have made them the preferred method of overcurrent protection

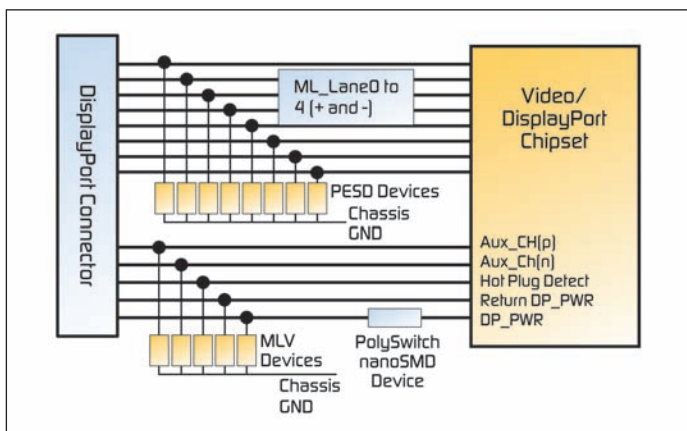

Figure 4. Typical DisplayPort circuit protection design utilizing MLV devices, PESD suppression devices and a PolySwitch overcurrent protection device

in many powered bus architectures.

Powered ports are also susceptible to damaging overvoltage transients, including ESD pulses. Figure 4 shows a typical circuit protection design utilizing a PolySwitch device for overcurrent protection, and PESD devices and multi-layer varistors (MLVs) to help protect against damage caused by overvoltage conditions.

The MLV provides low-capacitance shunt protection and offers the high current-handling and energy-absorption overvoltage protection required for LCD TV applications. The PESD arrays are installed over the data lines to help shunt ESD away from sensitive circuitry. The PESD device's low capacitance helps prevent degradation of high data rate signals.

As shown in Figure 5, LCD TVs host an array of accessory ports, including but not limited to, VGA, DVI, S-Video,

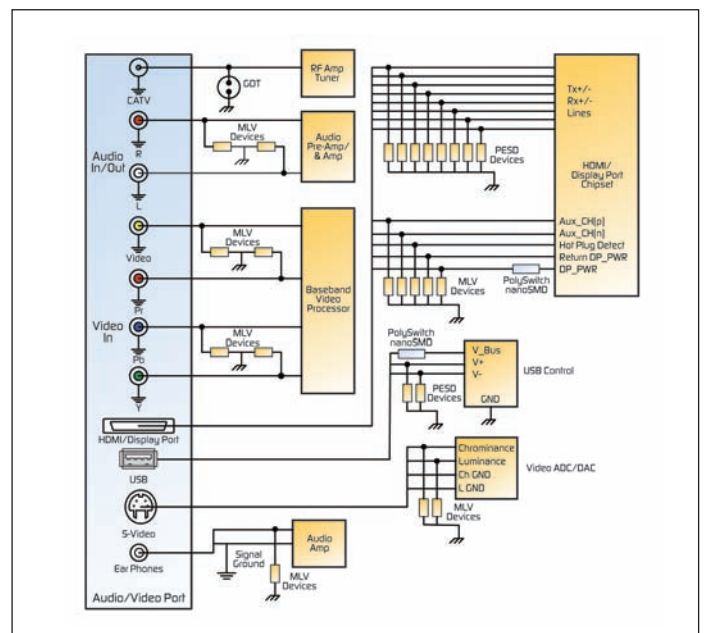

Figure 5: Circuit protection recommendations for LCD TV accessory ports

Composite Video and Audio Input/Output ports. This schematic shows how Tyco Electronics' Gas Discharge Tubes (GDTs), MLV, PESD and PolySwitch devices can be used in a coordinated circuit protection solution.

The VGA ports on LCD TVs allow for efficient connection from a computer video card. ESD or cable discharge events can contribute to VGA port failures. IEC 61000-4-2 requirements are applicable here, and low capacitance protection devices, such as the PESD and 3pF MLV devices (Figure 6), can help manufacturers comply with that standard. Note that here the signal line voltages are sub 1Vp-p on the RGB signal lines and 5Vp-p or less for the control lines.

It is always good practice to apply protection devices as close as possible to the chip sets' I/O and Vcc pins, as board traces may be susceptible to conducted transients. Good grounding practices coupled with robust circuit protection devices can

enhance transient protection, help reduce warranty returns and repair costs, and facilitate compliance with applicable standards.

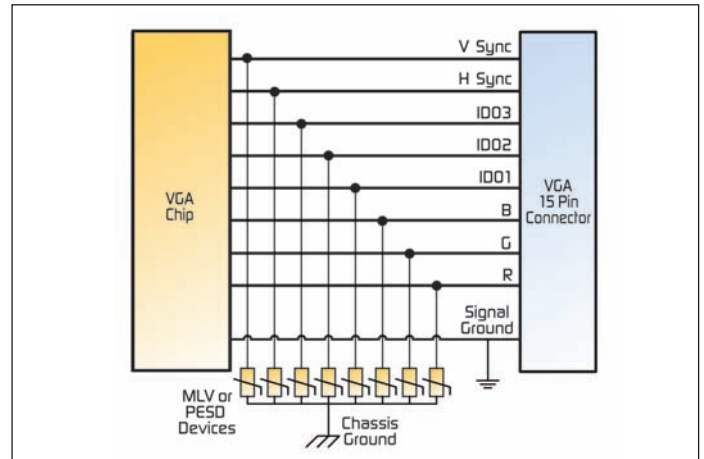

Figure 6: Low capacitance MLV and PESD devices help protect VGA ports

Device Recommendations

There are well defined requirements for fault protection at LCD TV interfaces, with specific standards addressing various fault protection needs. Figure 7 summarizes these standards and the recommended circuit protection devices for each port type.

Port Type	Overcurrent Protection	Overvoltage Protection	ESD Protection	Applicable Standard	Device Recommendation
USB	X		X	USB 2.0 and 3.0 IEC 6100-4-2 (ESD)	Surface-mount PolySwitch device MLV and PESD device
AC/DC	X	X		UL/IEC 60950 IEEE C62.41	PolySwitch LVR device ROV and/or GDT device
DVI, HDMI, VGA and Composite Video	X (for DP Power)		X	DVI 1.0 VGA HDMI 1.3	Surface-mount chip fuse Surface-mount PolySwitch device PESD device
RF Antenna	X	X		IEEE C62.41 Provider specific standards	Surface-mount chip fuse Surface-mount PolySwitch device GDT or PESD device
Audio			X	IEC 6100-4-2 (ESD)	MLV or PESD device
Ethernet (RJ45)	X PoE Management	X	X	IEEE 802.11a IEEE 802.11af/at (POE) IEC 6100-4-2 (ESD)	Surface-mount PolySwitch device Surface-mount chip fuse PESD device SiBar device
IEEE 1394	X		X	IEEE 1394 IEC 6100-4-2 (ESD)	Surface-mount PolySwitch device Surface-mount chip fuse MLV and PESD device SiBar device

Figure 7. Device recommendations for LCD TV port protection

Raychem Circuit Protection Products

308 Constitution Drive, Building H
Menlo Park, CA USA 94025-1164

Tel : (800) 227-7040, (650) 361-6900
Fax : (650) 361-4600

www.circuitprotection.com
www.circuitprotection.com.hk (Chinese)
www.tycoelectronics.com/japan/raychem (Japanese)

PolySwitch, SiBar, TE logo and Tyco Electronics are trademarks. All information, including illustrations, is believed to be reliable. Users, however, should independently evaluate the suitability of each product for their application. Tyco Electronics Corporation makes no warranties as to the accuracy or completeness of the information, and disclaims any liability regarding its use. Tyco Electronics' only obligations are those in the Tyco Electronics Standard Terms and Conditions of Sale for this product, and in no case will Tyco Electronics be liable for any incidental, indirect, or consequential damages arising from the sale, resale, use, or misuse of the product. Specifications are subject to change without notice. In addition, Tyco Electronics reserves the right to make changes without notification to Buyer—to materials or processing that do not affect compliance with any applicable specification.

© 2009 Tyco Electronics Corporation. All rights reserved. RCP0056E.0809

 **Tyco Electronics**
Our commitment. Your advantage.