

KIT_CSK_BGT60UTR11AIP

XENSIV™ Connected Sensor Kit

About this document

Scope and purpose

This user guide describes the function, circuitry, and performance of the XENSIV™ BGT60UTR11AIP Wing board, part of Infineon's XENSIV™ BGT60UTR11AIP Connected Sensor Kit ([KIT_CSK_BGT60UTR11AIP](#)).

Intended audience

The intended audience for this document is design engineers, technicians, and developers of electronic systems, working with Infineon's XENSIV™ 60 GHz radar sensors.

Reference Board/Kit

Product(s) embedded on a PCB with a focus on specific applications and defined use cases that may include software. PCB and auxiliary circuits are optimized for the requirements of the target application.

Note: Boards do not necessarily meet safety, EMI, quality standards (for example UL, CE) requirements.

Important notice

Important notice

“Evaluation Boards and Reference Boards” shall mean products embedded on a printed circuit board (PCB) for demonstration and/or evaluation purposes, which include, without limitation, demonstration, reference and evaluation boards, kits and design (collectively referred to as “Reference Board”).

Environmental conditions have been considered in the design of the Evaluation Boards and Reference Boards provided by Infineon Technologies. The design of the Evaluation Boards and Reference Boards has been tested by Infineon Technologies only as described in this document. The design is not qualified in terms of safety requirements, manufacturing and operation over the entire operating temperature range or lifetime.

The Evaluation Boards and Reference Boards provided by Infineon Technologies are subject to functional testing only under typical load conditions. Evaluation Boards and Reference Boards are not subject to the same procedures as regular products regarding returned material analysis (RMA), process change notification (PCN) and product discontinuation (PD).

Evaluation Boards and Reference Boards are not commercialized products, and are solely intended for evaluation and testing purposes. In particular, they shall not be used for reliability testing or production. The Evaluation Boards and Reference Boards may therefore not comply with CE or similar standards (including but not limited to the EMC Directive 2004/EC/108 and the EMC Act) and may not fulfill other requirements of the country in which they are operated by the customer. The customer shall ensure that all Evaluation Boards and Reference Boards will be handled in a way which is compliant with the relevant requirements and standards of the country in which they are operated.

The Evaluation Boards and Reference Boards as well as the information provided in this document are addressed only to qualified and skilled technical staff, for laboratory usage, and shall be used and managed according to the terms and conditions set forth in this document and in other related documentation supplied with the respective Evaluation Board or Reference Board.

It is the responsibility of the customer’s technical departments to evaluate the suitability of the Evaluation Boards and Reference Boards for the intended application, and to evaluate the completeness and correctness of the information provided in this document with respect to such application.

The customer is obliged to ensure that the use of the Evaluation Boards and Reference Boards does not cause any harm to persons or third party property.

The Evaluation Boards and Reference Boards and any information in this document is provided "as is" and Infineon Technologies disclaims any warranties, express or implied, including but not limited to warranties of non-infringement of third party rights and implied warranties of fitness for any purpose, or for merchantability.

Infineon Technologies shall not be responsible for any damages resulting from the use of the Evaluation Boards and Reference Boards and/or from any information provided in this document. The customer is obliged to defend, indemnify and hold Infineon Technologies harmless from and against any claims or damages arising out of or resulting from any use thereof.

Infineon Technologies reserves the right to modify this document and/or any information provided herein at any time without further notice.

Safety precautions

Safety precautions

Note: Please note the following warnings regarding the hazards associated with development systems.

Table 1 Safety precautions

	<p>Caution: The evaluation or reference board contains parts and assemblies sensitive to electrostatic discharge (ESD). Electrostatic control precautions are required when installing, testing, servicing or repairing the assembly. Component damage may result if ESD control procedures are not followed. If you are not familiar with electrostatic control procedures, refer to the applicable ESD protection handbooks and guidelines.</p>
---	--

Table of contents

Table of contents

About this document..... 1

Important notice 2

Safety precautions..... 3

Table of contents..... 4

1 The board at a glance..... 5

1.1 Scope of supply 6

1.2 Block diagram..... 6

1.3 Main features 8

1.4 Board parameters and technical data..... 8

2 System design 9

2.1 Schematics 10

2.2 Layout 13

2.3 Bill of materials..... 13

2.4 Connector details 15

References.....18

Glossary19

Revision history.....20

Disclaimer.....21

1 The board at a glance

1 The board at a glance

The XENSIV™ BGT60UTR11AIP Connected Sensor Kit supports customers in testing sensor-driven IoT products and radar use cases as well as in prototyping. It offers a real-time sensor evaluation with custom configurations and cloud- and radar-based solution output visualization. The KIT_CSK_BGT60UTR11AIP (Figure 1) comes with:

- Rapid IoT Connect Developer Kit (CYSBSYSKIT-DEV-01)
- XENSIV™ BGT60UTR11AIP Wing (EVAL_60UTR11_WING)

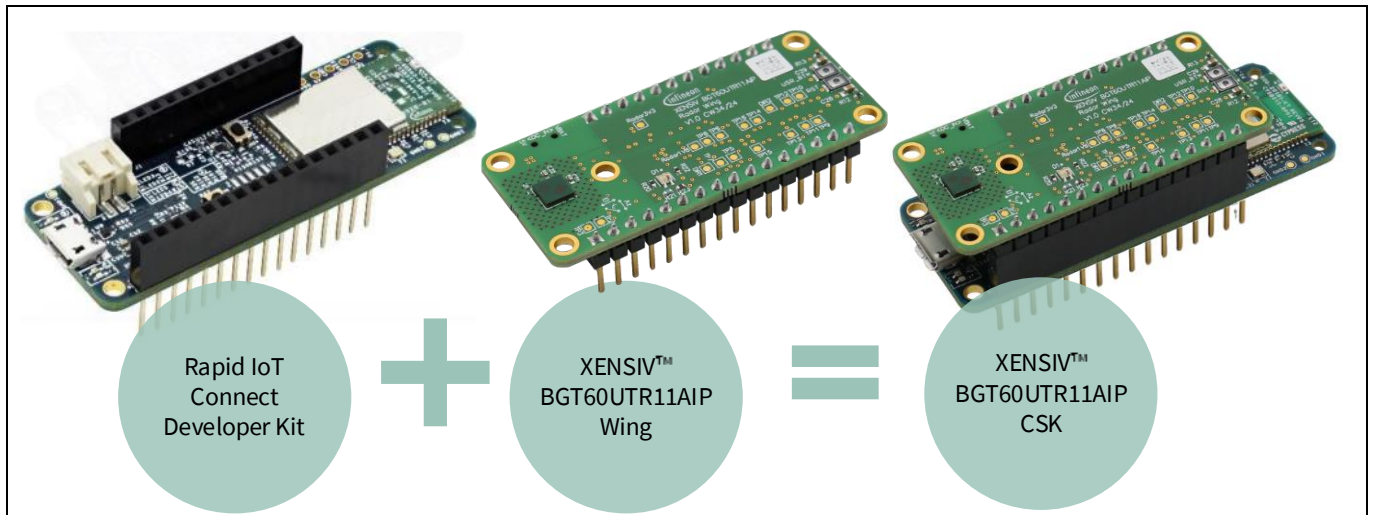

Figure 1 XENSIV™ BGT60UTR11AIP Connected Sensor Kit

The Rapid IoT Connect Developer Kit (CYSBSYSKIT-DEV-01) shown in Figure 2 allows the evaluation of the Rapid IoT Connect module (CYSBSYS-RP01) on a standard Feather form-factor. The CYSBSYS-RP01 Rapid IoT Connect module is a turnkey module that enables secure, scalable, and reliable compute and connect.

The Rapid IoT Connect Developer Kit carries a CYSBSYS-RP01 Rapid IoT connect system-on-module (SoM), which includes a PSoC™ 6 MCU, an AIROC™ CYW43012 single-chip radio, onboard crystals, oscillators, chip antenna, and passive components.

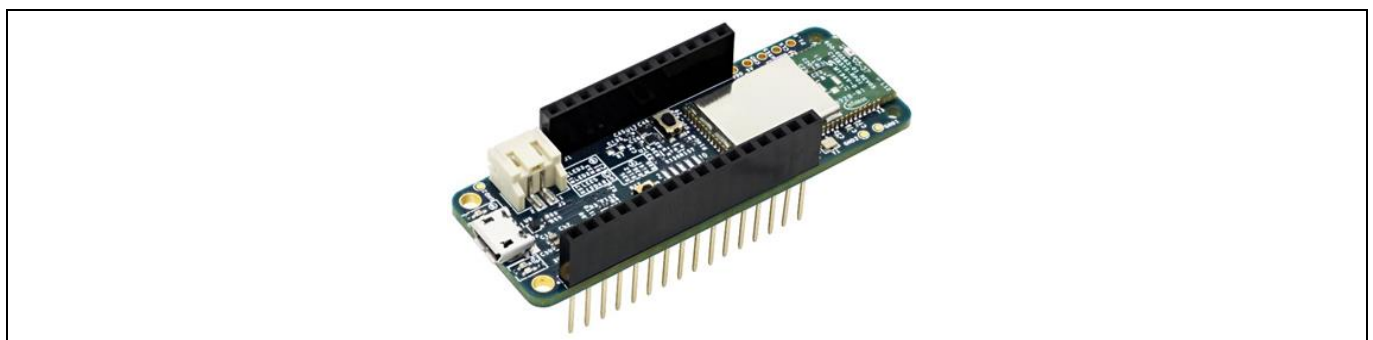

Figure 2 Rapid IoT Connect Developer Kit

1 The board at a glance

The XENSIV™ BGT60UTR11AIP Wing board shown in [Figure 3](#) is based on the XENSIV™ BGT60UTR11AIP 60 GHz radar sensor MMIC with one transmitting and one receiving antenna integrated. The XENSIV™ BGT60UTR11AIP MMIC enables ultra-wide bandwidth FMCW operation. It is equipped with an integrated finite state machine (FSM). With the aid of the FSM, the XENSIV™ BGT60UTR11AIP can perform frequency modulated continuous wave (FMCW) frequency sweeps (chirps), acquire data, and store samples into the internal first-in, first-out (FIFO) memory autonomously.

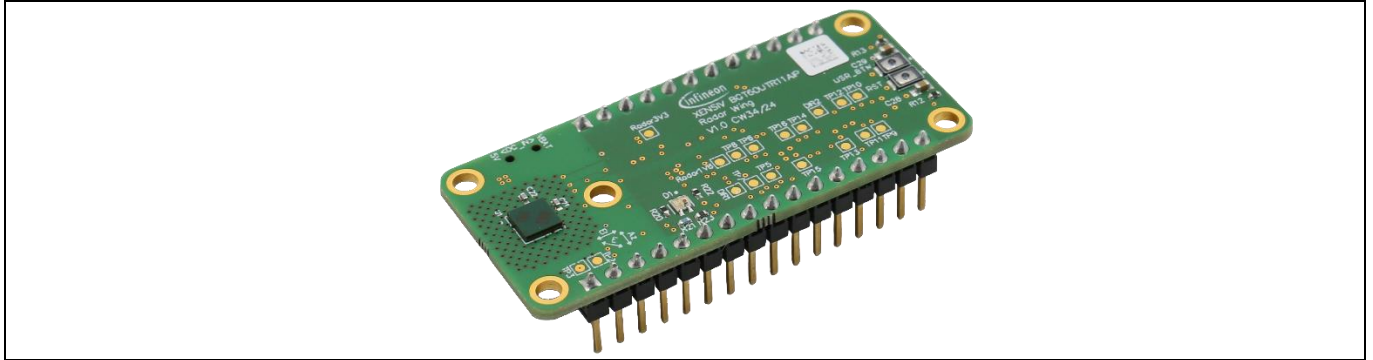

Figure 3 XENSIV™ BGT60UTR11AIP Wing board

1.1 Scope of supply

The kit can be powered from a 3.7 V LiPo battery or via a USB cable from an external 5 V power supply. The battery is automatically charged when the system is connected to an external power supply.

Note: The radar wing board must be manually switched to either battery or external 5 V supply (switch S3 in [Figure 13](#)).

1.2 Block diagram

A block diagram of the wing board is shown in [Figure 4](#). The wing board comprises the XENSIV™ BGT60UTR11AIP radar sensor and the required power supply components. Power lines are highlighted in red. It is also equipped with push buttons and LEDs.

1 The board at a glance

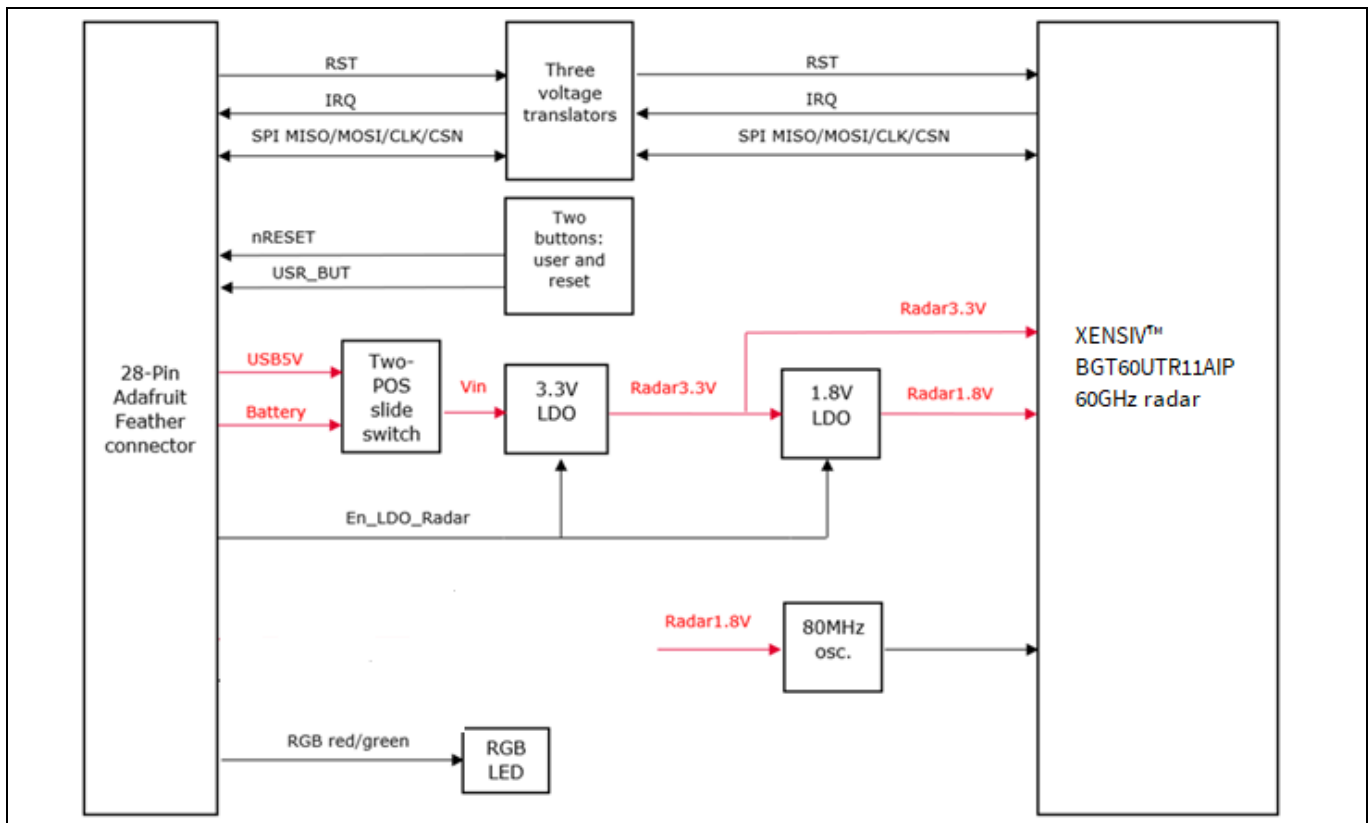

Figure 4 XENSIV™ BGT60UTR11AIP Wing board block diagram

A system block diagram showing the shield connected to the CSK rapid IoT baseboard is shown in [Figure 4](#). The interface from the shield to the rapid IoT baseboard includes I2C, digital signals, analog signals and power lines. The baseboard can interact with the outside world using Wi-Fi, Bluetooth®, USB, or a combination of them depending on the firmware/software (FW/SW) installed on the baseboard. The kit can be powered from an external power supply or from a LiPo battery.

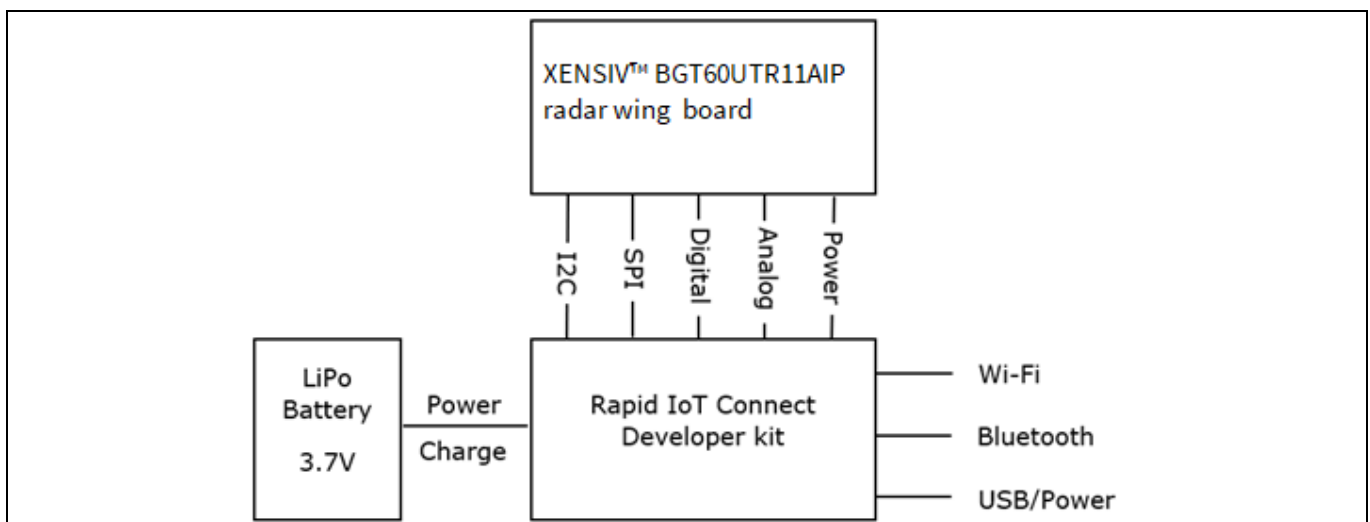

Figure 5 CSK system block diagram

1 The board at a glance

1.3 Main features

- XENSIV™ BGT60UTR11AIP MMIC
 - 4.05 mm x 4.05 mm x 0.86 mm package size
 - 1Tx 1Rx Antennas in Package (AIP) with 90°x120° FoV (3 dB HPBW)
 - Real time data acquisition without interaction with the processor
 - Three different power modes provide the user full flexibility between performance and power consumption optimizations
- XENSIV™ BGT60UTR11AIP Wing board
 - 50.8 mm x 22.9 mm size on standard FR4 laminate
 - 1 RGB LED and 2 configurable user buttons on the wing
 - Form-factor compatibility with Adafruit
- CYSBSYSKIT-DEV-01 Rapid IoT Connect Developer Kit (MCU board)
 - Operates with ModusToolbox™ and Infineon Rapid IoT Connect cloud platform

1.4 Board parameters and technical data

Table 2 Parameters

Parameter	Symbol	Conditions	Value	Unit
Supply voltage	–	–	3.3 (wing board) 1.8 (MMIC)	V
MMIC power consumption	–	10 Hz duty cycle	1	mW
Operating frequency	–		57.4 to 63	GHz
EIRP	–	–	+9	dBm
Antenna in Package FoV	–	–	90° x 120° (3 dB HPBW)	degree

2 System design

2 System design

This section introduces you to the various features of the XENSIV™ BGT60UTR11AIP Radar Wing board. Apart from the headers, all components are mounted on the top side of the Wing board, which has male headers facing downwards to either plug the board directly on the Rapid IoT baseboard or on top of another Wing board such as the Infineon XENSIV™ PAS CO2 Wing board.

Figure 6 and Table 3 provide a description of the components mounted on the XENSIV™ BGT60UTR11AIP Radar Wing board.

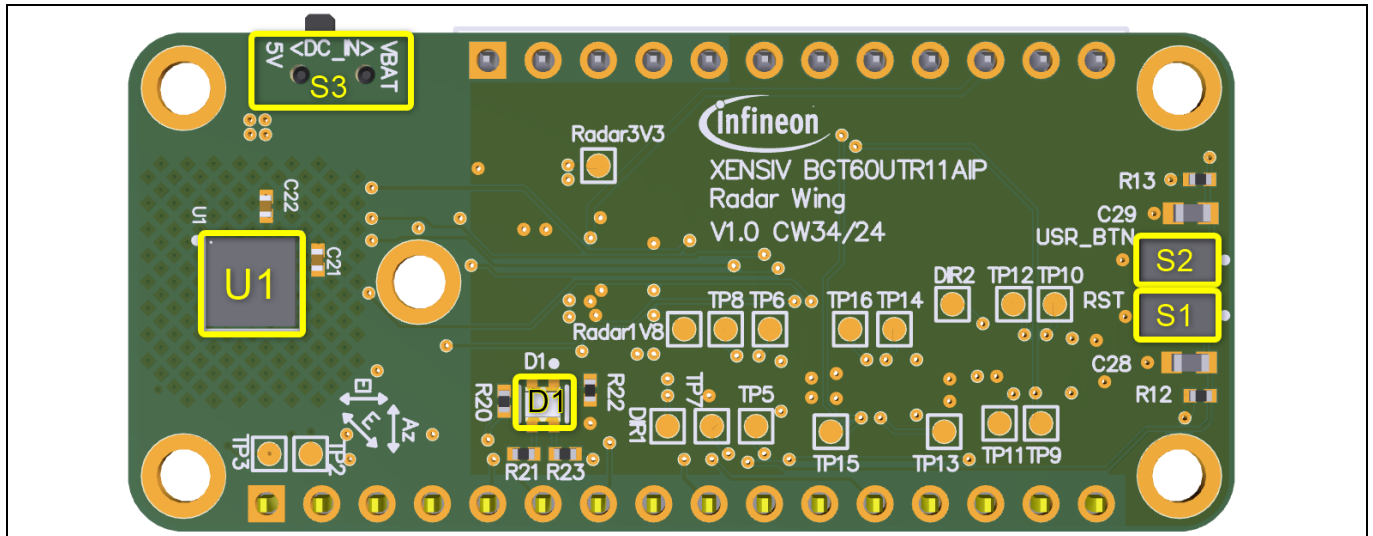

Figure 6 Front view of the XENSIV™ BGT60UTR11AIP Radar Wing board

Table 3 Onboard hardware

Ref designator	Function
U1	XENSIV™ BGT60UTR11AIP device
X1	80 MHz CMOS oscillator
D1	Tri-color LED
S1	System reset button; active LOW
S2	User button; active LOW
S3	To select the board power supply from CYCBSYSKIT-DEV-01 Rapid IoT baseboard: USB5V or from LiPo battery supply of the kit
J1, J2	Adafruit headers

2 System design

2.1 Schematics

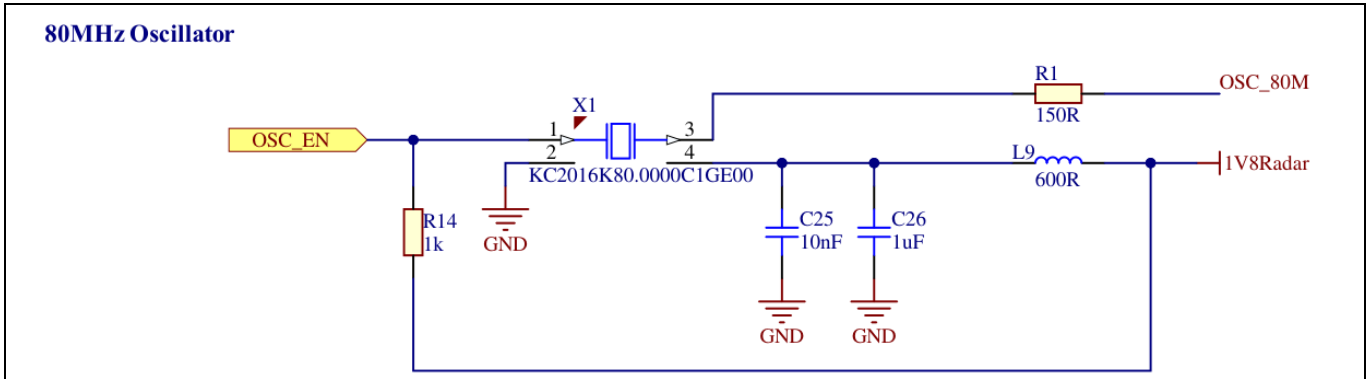

Figure 7 Oscillator circuit on the XENSIV™ BGT60UTR11AIP Wing board

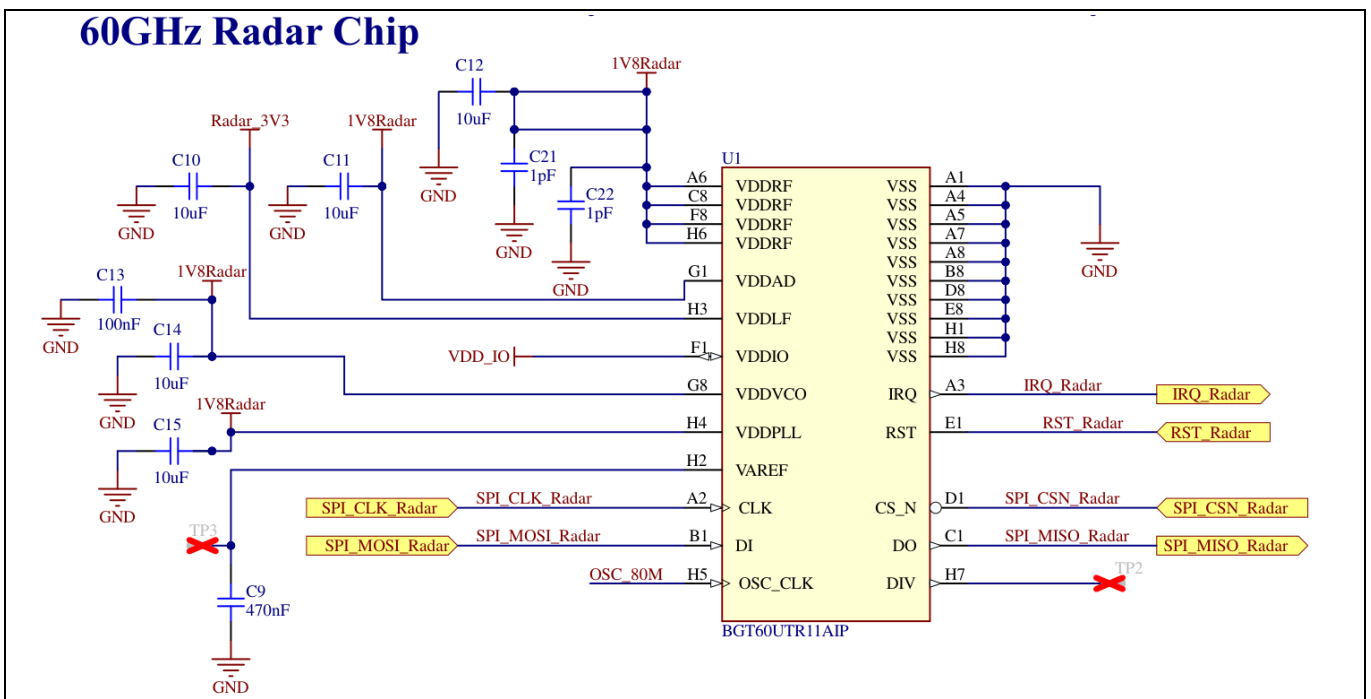

Figure 8 XENSIV™ BGT60UTR11AIP Radar MMIC schematic

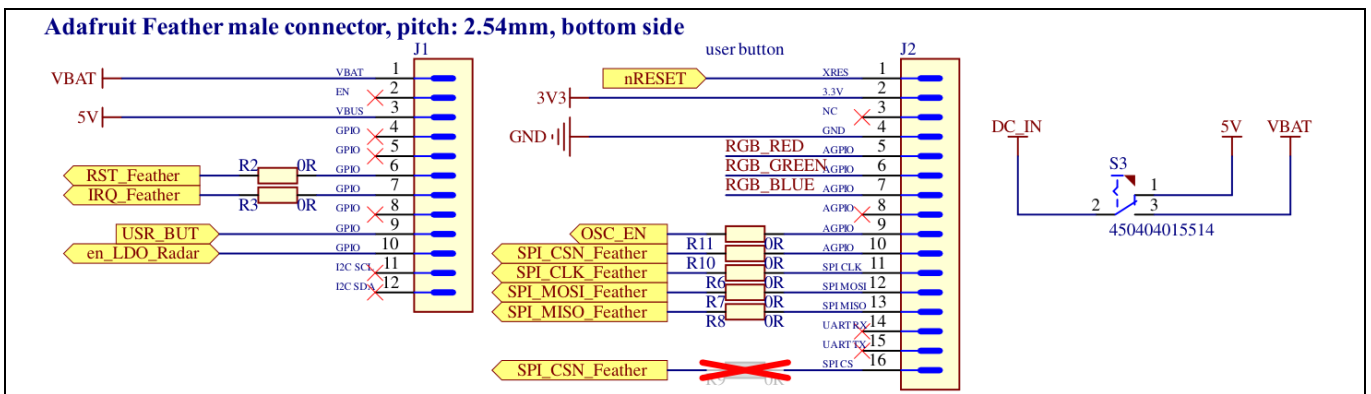

Figure 9 Adafruit header schematic

2 System design

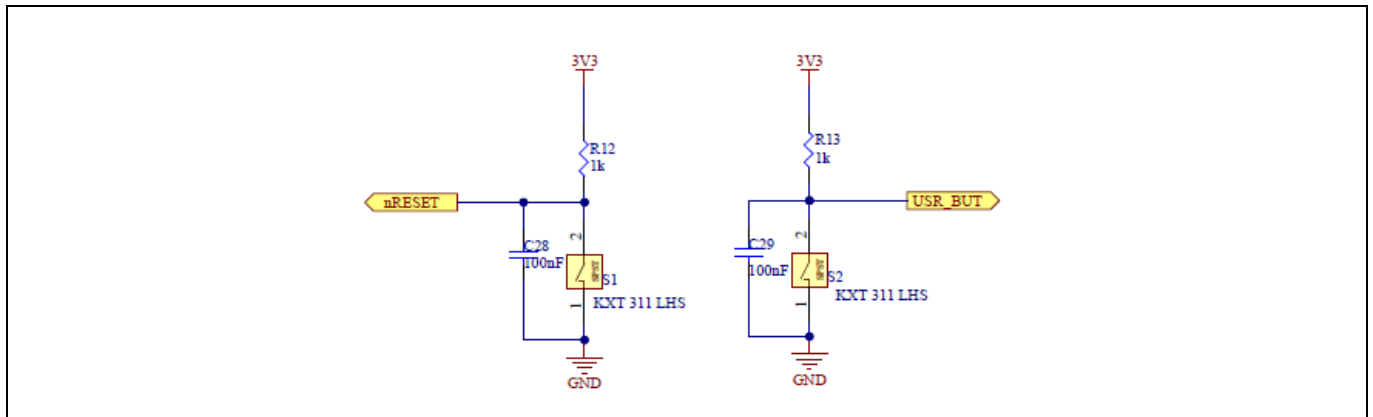

Figure 10 XENSIV™ BGT60UTR11AIP Radar MMIC schematic

The user interface on the wing board consists of two mechanical buttons (Figure 11) and three LEDs (Figure 12).

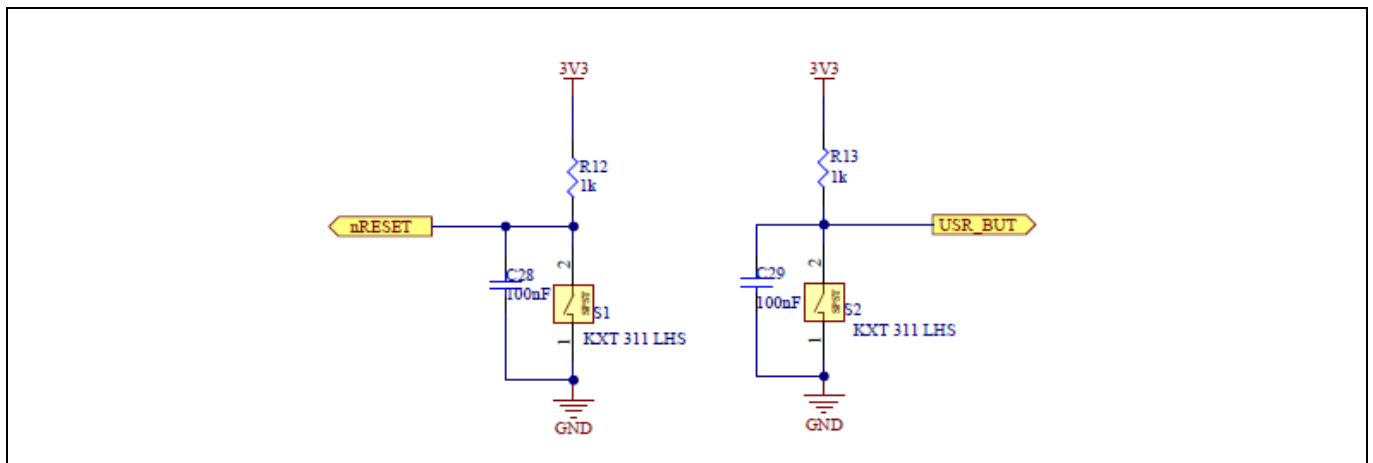

Figure 11 Reset (S1) and user button (S2) schematic

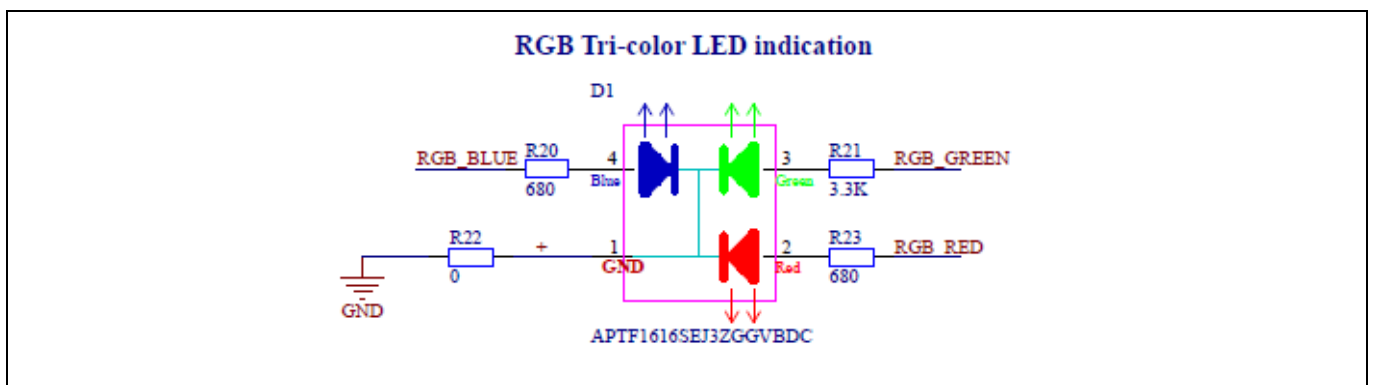

Figure 12 LEDs schematic

Figure 13 shows the board power selection schematic.

2 System design

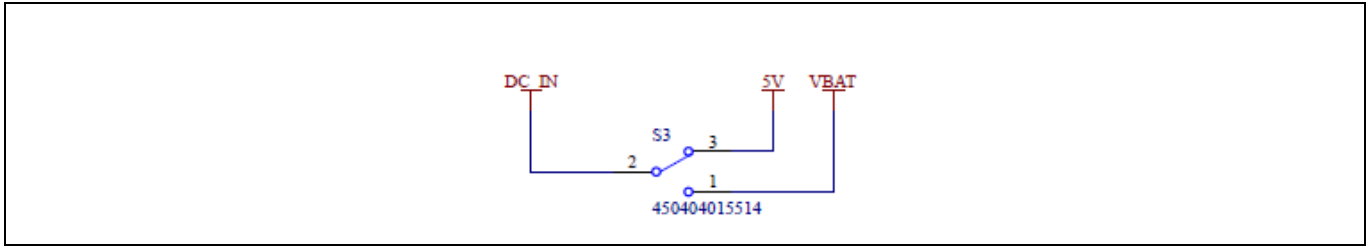

Figure 13 Board power selection (S3) schematic

Figure 14 shows the voltage regulator circuit to provide stable power supply to the radar sensor.

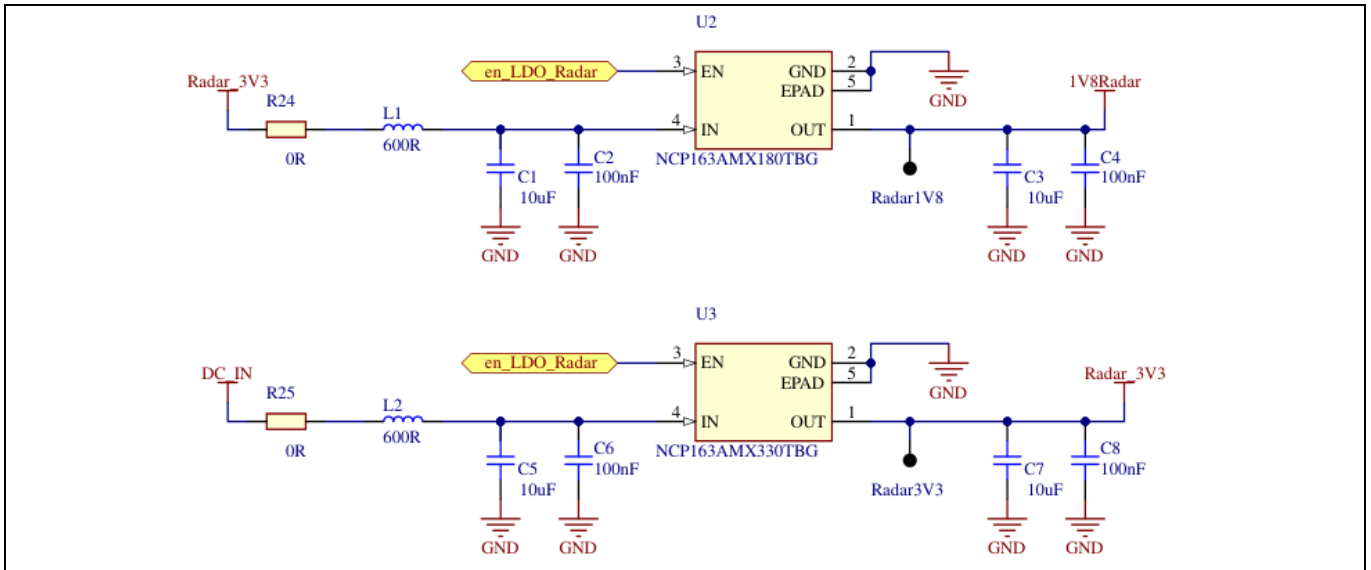

Figure 14 Voltage supply for radar sensor

Figure 15 shows the pin assignment of J1 and J2 on the XENSIV™ BGT60UTR11AIP Radar Wing board. The Adafruit feather-compatible header is used to plug into the CYCBSYSKIT-DEV-01 Rapid IoT Connect Developer Kit.

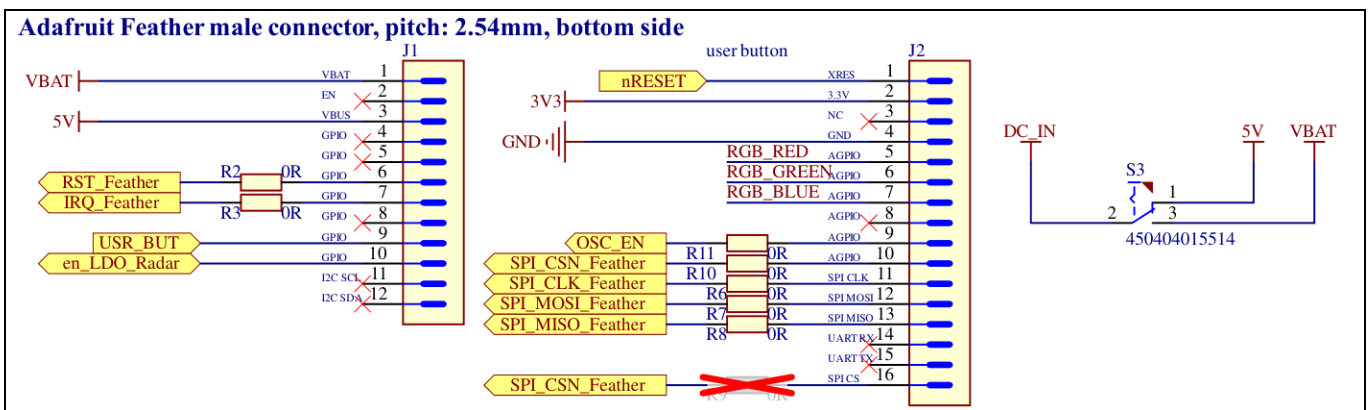

Figure 15 Adafruit headers schematic

2 System design

2.2 Layout

The size of the XENSIV™ BGT60UTR11AIP Radar Wing board is 43 mm (L) x 23 mm (W), as shown in [Figure 16](#).

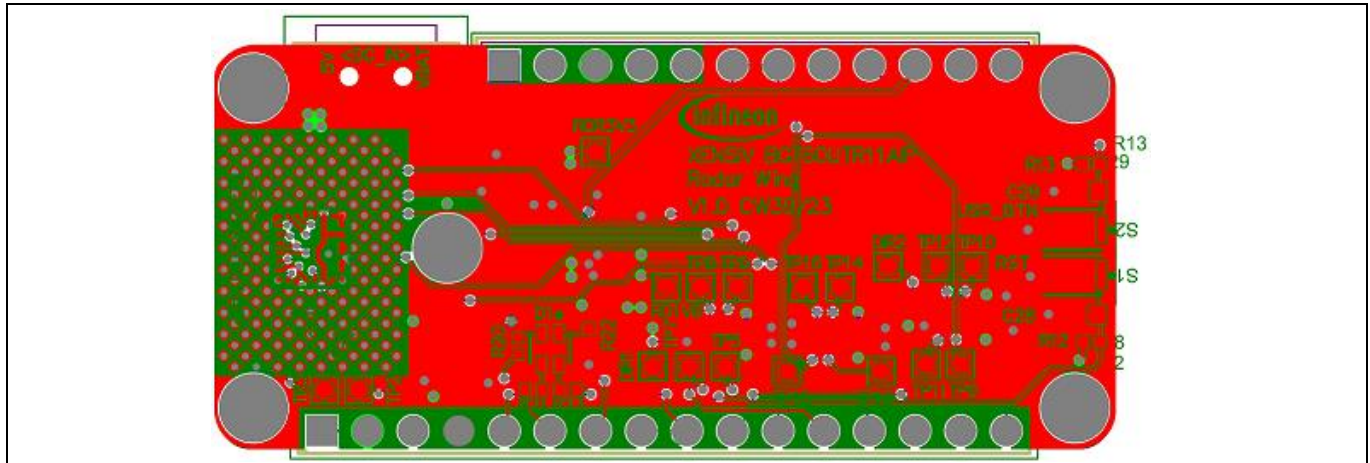

Figure 16 PCB layout of XENSIV™ BGT60UTR11AIP Radar Wing board

2.3 Bill of materials

The complete bill of materials (BOM) is available on the Design Support section of the [KIT_CSK_BGT60UTR11AIP](#) product webpage.

Table 4 BOM of the most important/critical parts of the evaluation or reference board (example)

Ref designator	Description	Manufacturer	Manufacturer P/N	Footprint	Qty
C1, C3, C5, C7, C10, C11, C12, C14, C15	10 µF ±20% 6.3V Ceramic Capacitor X6S 0402 (1005 Metric)	Murata	GRM155C80J10 6ME11D	CAPC1005X70 N	9
C2, C4, C6, C8, C13, C30, C31, C32, C33, C34, C35	0.1 µF ±20% 10V Ceramic Capacitor X5R 0201 (0603 Metric) 0.1 µF 10V Ceramic Capacitor X7R 0201	Murata	GRM033R61A10 4ME15D, GRM033Z71A10 4KE14D	CAPC0603X33 N	11
C9	0.47 µF 10 V Ceramic Capacitor X6S 0201	Taiyo Yuden	LMK063BC6474 KPLF	CAPC0603X39 N	1
C16, C18, C26	1 µF ±20% 6.3V Ceramic Capacitor X7T 0201 (0603 Metric)	Murata	CAPC0603X35N	GRM033D70J1 05ME01D	3
C25	10000 pF ±10% 10V Ceramic Capacitor X7R 0201 (0603 Metric)	Murata	CAPC0603X33N	GCM033R71A1 03KA03D	1
C28, 29	0.1 µF 6.3 V Ceramic Capacitor X7R 0603	KEMET	CAPC1608X87N	C0603C104K5R ACTU	2
–	Full-Color Surface Mount LED, 520nm, Green, Low power consumption	KINGBRIGHT	LED-SMD- APTF1616SEJ3Z GGVBC	APTF1616SEJ3 ZGGVBDC	1

2 System design

Ref designator	Description	Manufacturer	Manufacturer P/N	Footprint	Qty
DIR1, IR2, RD1V8, DR3V3, TP2, TP3, TP5, TP6, TP7, TP8, TP9, TP10, TP11, P12, TP13, P14, TP15, P16	Generic Surface Mount TP with 1 mm diameter	N.A	TP	TP SMD	18
J1	Header, 12-pin, pitch 2.54 mm, vertical, single row	Molex	HDRV12W64P254_1X12_3048X254X898B	TSW-112-07-L-S	1
J2	Header, 16-pin, pitch 2.54 mm, vertical, single row	Molex	HDRV16W64P254_1X16_4070X254X838B	TSW-116-07-L-S	1
L1, L2	Ferrite bead 600 Ω at 100 MHz ferrite bead 0201 (0603 metric) 250 mA 850 mΩ	Murata	INDC0603X33N	BLM03AX601SN1D	2
L9	Ferrite bead 600 Ω at 100 MHz signal line ferrite bead 0402 (1005 metric) 200 mA 850 mΩ	TDK	INDC1005X55N_MMZ1005	MMZ1005B601CT000	1
R1	Resistor SMD 150 Ω 1% 1/20 W 0201	Yageo	RESC0603X26N	AC0201FR-07150RL	1
R2, R3, R4, R6, R7, R8, R10, R11, R22, R24, R25	Resistor SMD 0 Ω jumper 1/16 W 0402	TE Connectivity Passive Product	RESC1005X03N	CRG0402ZR	11
R12, R13	Resistor SMD 1k Ω 5% 1/10 W 0402	Panasonic Electronic Components	RESC1005X40N	ERJ-2GEJ102X	2
R14, R18, R19	Resistor SMD 1k Ω 1% 1/20 W 0201	Panasonic Electronic Components	RESC0603X26N	ERJ-1GNF1001C	3
R16	Resistor SMD 0 Ω jumper 1/20 W 0201	Vishay Dale	RESC1005X03N	CRCW02010000ZOED	1
R20, R23	Resistor SMD 680 Ω 5% 1/16 W 0402	Yageo	RESC1005X40N	CRCW0402680RFK	2
R21	3.3 kOhms ±1% 0.1W, 1/10W Chip Resistor 0402 (1005 Metric)	Panasonic Electronic Components	RESC1005X40N	ERJ-2RKF3301X	1
S1, S2	KXT 311 LHS, tactile switch SPST-NO 0.02 A 15 V, KXT3 Series ultra low profile top actuated, 100 g, SPST	C&K	SW-SMD-KXT311LHS	KXT311LHS	2

2 System design

Table 5 Adafruit Feather-compatible pinout

Header mapping	Primary onboard function	PSOC™ 6 MCU pin (Rapid IoT baseboard)	Adafruit Feather-compatible mapping (Rapid IoT baseboard)	Adafruit Feather-compatible mapping (BGT60UTR11AIP Radar Wing board)	Details
J1.1	VBAT	–	–	VBAT	LiPo battery voltage
J1.2	EN	–	–	–	Not connected
J1.3	VBUS	–	–	5 V	USB power
J1.4	GPIO	P9_0	GPIO13	–	Not connected
J1.5	GPIO	P9_1	GPIO12	–	Not connected
J1.6	GPIO	P9_2	GPIO11	RST_Feather	RST
J1.7	GPIO	P9_3	GPIO10	IRQ_Feather	IRQ
J1.8	GPIO	P9_4	GPIO9	–	Not connected
J1.9	GPIO	P9_7	GPIO6	USR_BUT	User button
J1.10	GPIO	P8_4	GPIO5	en_LDO_Radar	Enable the LDOs (3.3 V and 1.8 V) on radar Wing board for radar sensor
J1.11	I ² C SCL	P6_0	SCL	I2C_SCL_Feather	Connected to KitProg3. Note that this pin has a 4.7 kΩ pull-up for I ² C communication
J1.12	I ² C SDA	P6_1	SDA	I2C_SDA_Feather	Connected to KitProg3. Note that this pin has a 4.7 kΩ pull-up for I ² C communication
J2.1	XRES	XRES	XRES	nRESET	Reset button
J2.2	3.3 V	VDDA, VDDIO	VCC	3V3	Analog voltage for PSOC™ 6 MCU
J2.3	NC	–	NC	–	Not connected
J2.4	GND	–	GND	GND	Ground
J2.5	Analog GPIO	P10_0	A0	RGB_RED	RGB red color
J2.6	Analog GPIO	P10_1	A1	RGB_GREEN	RGB green color
J2.7	Analog GPIO	P10_2	A2	RGB_BLUE	RGB blue color
J2.8	Analog GPIO	P10_3	A3	–	Not connected
J2.9	Analog GPIO	P10_4	A4	–	Not connected
J2.10	Analog GPIO	P10_5	A5	SPI_CSN_Feather	SPI Chip Select

2 System design

Header mapping	Primary onboard function	PSOC™ 6 MCU pin (Rapid IoT baseboard)	Adafruit Feather-compatible mapping (Rapid IoT baseboard)	Adafruit Feather-compatible mapping (BGT60UTR11AIP Radar Wing board)	Details
J2.11	SPI Clock	P5_2	SCK	SPI_CLK_Feather	SPI clock
J2.12	SPI MOSI	P5_0	MOSI	SPI_MOSI_Feather	SPI Master Out/Slave IN (MOSI)
J2.13	SPI MISO	P5_1	MISO	SPI_MISO_Feather	SPI Master In/Slave OUT (MISO)
J2.14	UART RX	P6_4	RX	–	Not connected
J2.15	UART TX	P6_5	TX	–	Not connected
J2.16	SPI CS	P5_3	GPIO	–	Not connected

References

References

- [1] Infineon Technologies AG. *BGT60UTR11AIP MMIC datasheet*; [Available online](#)
- [2] Infineon Technologies AG: *Getting started with PSOC™ 6 MCU on ModusToolbox™ application note*; [Available online](#)
- [3] Infineon Technologies AG: *Code examples for ModusToolbox™*; [Available online](#)

Glossary

Glossary

BSP

board support package (BSP)

CSK

connected sensor kit (CSK)

FMCW

frequency modulated continuous wave (FMCW)

FSM

finite state machine (FSM)

GPIO

general-purpose input/output (GPIO)

HW

hardware (HW)

I²C

inter-integrated circuit (I²C)

IoT

internet of things (IoT)

LED

light-emitting diode (LED)

PAS

photoacoustic spectroscopy (PAS)

PCB

printed circuit board (PCB)

SPI

serial peripheral interface (SPI)

UART

Universal asynchronous receiver transmitter (UART)

Revision history

Revision history

Document revision	Date	Description of changes
1.00	2025-03-18	Initial release

Trademarks

All referenced product or service names and trademarks are the property of their respective owners.

PSOC™, formerly known as PSoC™, is a trademark of Infineon Technologies. Any references to PSoC™ in this document or others shall be deemed to refer to PSOC™.

Edition 2025-03-18

Published by

Infineon Technologies AG

81726 Munich, Germany

© 2025 Infineon Technologies AG.

All Rights Reserved.

Do you have a question about this document?

Email: erratum@infineon.com

Document reference

UG143158

Warnings

Due to technical requirements products may contain dangerous substances. For information on the types in question please contact your nearest Infineon Technologies office.

Except as otherwise explicitly approved by Infineon Technologies in a written document signed by authorized representatives of Infineon Technologies, Infineon Technologies' products may not be used in any applications where a failure of the product or any consequences of the use thereof can reasonably be expected to result in personal injury.